



MSWV Series

Multi-stage Centrifugal Pumps

Installation, Operating and Maintenance Manual



CSA standard applies to pump & motor unit.





Table of Contents

- 1. Application**
- 2. Product Code Designation**
- 3. Operating Limits**
- 4. Installation**
- 5. Electrical Connection**
- 6. Start-up**
- 7. Operation and Maintenance**
- 8. Sound Level**
- 9. Wiring diagram**
- 10. Troubleshooting**
- 11. Dimensions and Weights**



EC Declaration of Conformity

Manufacturer representative:

Price Pump Co.

Address:

21775 Eighth Street East, Sonoma, CA 95476 USA

Declare that the machinery described: Name:

Water Pump

Model: MSWV Series

Conform to the following directive:

98/37/EC-----Machinery directive

2006/95/EC—Low voltage directive

89/336/EEC----EMC (Electromagnetic compatibility) directive

Refer to the following standards:

EN ISO 12100-1:2003

EN ISO 12100-2:2003

EN1050:1996

EN60335-1:2001

EN 809:1998

EN60335-2-41:2001

EN61000-6-2

EN61000-6-3

QC Department Manager: Joe Keechler

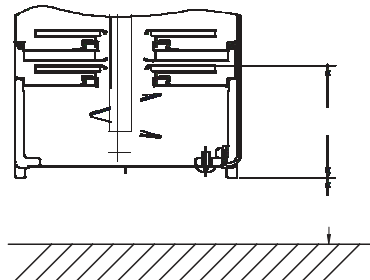

5. Electrical Connection



5.1 The electrical connection should be carried out in accordance with local regulations. Never make any connections unless the electricity supply has been switched off.



5.2. The electrical hazard warning mark is placed outside the connection box. Be careful.

5.3. Electrical data (voltage, frequency and phase) are shown on the pump nameplate. Verify that this data matches your electrical supply. A circuit breaker should be installed and the grounding be properly connected for your safety.

5.4. Make electrical connection in accordance with connecting diagram located inside the connection box. The motor current must be within the rated amps range indicated on nameplate. Three-phase motor requires a magnetic starter for safety.

5.5. For three phase motors, please check the correct direction of rotation of the pump on the motor fan cover. When seen from motor fan cover end, the pump should rotate clockwise. You can reverse the direction of rotation by interchanging any two of the incoming supply wires.

6. Start-up

Before starting the pump, make sure the following:

6.1. For three phase motors, verify if the rotating direction is correct. It should be clockwise viewing from the motor fan cover end.

6.2. All piping joints are completely tight. Leakage in piping may cause the pump hydraulic loss.

6.3. The pump is filled with liquid.

6.4. The suction filter is not blocked by any foreign objects.

7. Operation and Maintenance



It is dangerous to operate the pump against a closed discharge outlet because it will cause extremely high liquid flow temperature and damage the pump in a few minutes.

7.1. Lubrication

The mechanical seal and shaft sleeves are lubricated by the pumped liquid.

7.2. Suction filter

Always keep suction filter clean and make sure it is not blocked by impurities.

7.3. Periodic checks

The following checks should be carried out periodically to ensure the normal operation.

7.3.1. Check the quantity of liquid and operating pressure.

7.3.2. Check there are no leaks on piping joints.

7.3.3. Check the tripping of the motor starter.

7.3.4. Check that all controls are functioned normally.

7.4. The pump must not be used to transfer explosive liquids. In systems with hot liquids (over 140°F), extra caution should be exercised to prevent from personal injury.

7.5. The pump should not be used to transfer toxic or contaminated liquids. Please carefully follow all instructions in the manual as Price Pump Company may refuse to accept a contaminated pump for servicing.

8. Sound Level

Model	dB(A)
1MSWV - ** - 2	<70
2MSWV - ** - 2	<70
3MSWV - ** - 2	<70
4MSWV - ** - 2	<70
5MSWV - ** - 2	<70
6MSWV - ** - 2	<70
7MSWV - ** - 2	<70

Model	dB(A)
1MSWV - ** - 4	<70
2MSWV - ** - 4	<70
3MSWV - ** - 4	<70
4MSWV - ** - 4	<70
5MSWV - ** - 4	<70
6MSWV - ** - 4	<70
7MSWV - ** - 4	<70

Model	dB(A)
2MSWV - ** - 8	72
3MSWV - ** - 8	72
4MSWV - ** - 8	76
5MSWV - ** - 8	76

Model	dB(A)
1MSWV - ** - 12	72
2MSWV - ** - 12	76

9. Wiring diagram

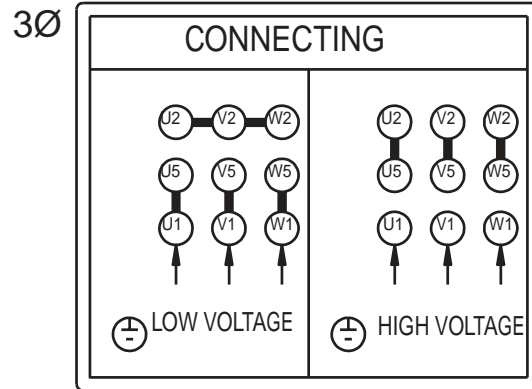

10. Troubleshooting

Make sure electricity supply has been switched off before attempting to diagnose any fault

Fault	Cause
10.1. Motor does not start	a. No electricity supply
	b. Fuses are blown.
	c. Motor overheating - relay tripped.
	d. Defective magnetic contactors.
	e. Control circuit malfunction.
10.2. Motor cut out during operation.	a. Fuses blown or breakers tripped.
	b. Overheating relay tripped.
	c. Control circuit malfunction.
	d. Pump locked up by foreign objects.
10.3. Pumped capacity is not constant.	a. Pump impeller blocked by impurities.
	b. Insufficient liquid level in the tank. (See Sec. 4.1)
10.4. Pump runs but gives no liquid.	a. Suction filter blocked by impurities.
	b. Liquid level is too low (See Sec. 4.1)
	c. Incorrect rotating direction.

MSWV-2/4

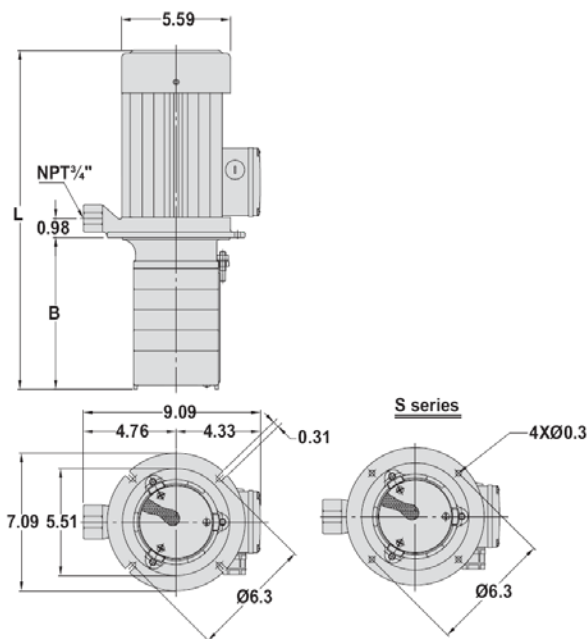

MSWV-8/12

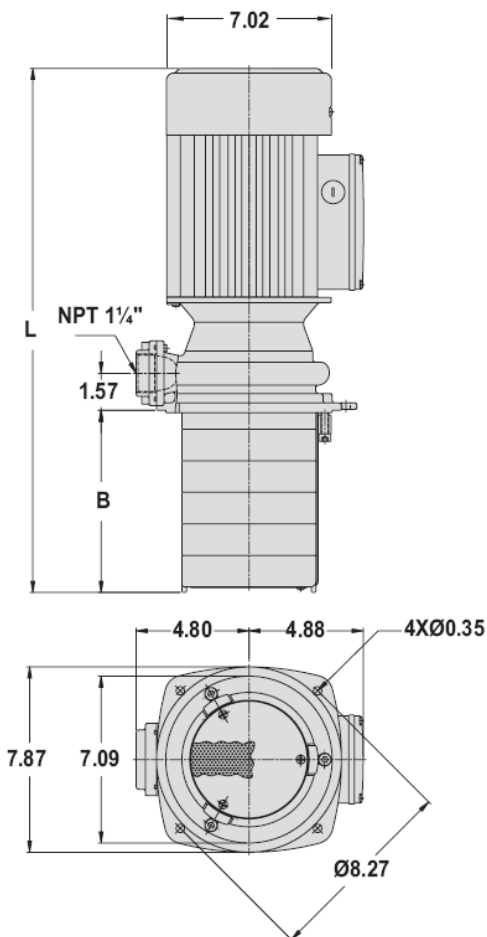

11. Dimensions and Weights

BOM	Model	B (in.)	L (in.)	N.W. (lbs)
TPHK 2T 3 -1	1MSWV-3-2	5.71	13.78	24.0
TPHK 2T 8 -1	1MSWV-8-2	9.25	17.32	26.2
TPHK 2T 3 -2	2MSWV-3-2	5.71	13.78	24.5
TPHK 2T 5 -2	2MSWV-5-2	7.13	15.20	25.4
TPHK 2T 9 -2	2MSWV-9-2	9.96	18.03	27.1
TPHK 2T 3 -3	3MSWV-3-2	5.71	13.78	24.7
TPHK 2T 4 -3	3MSWV-4-2	6.42	14.49	25.1
TPHK 2T 5 -3	3MSWV-5-2	7.13	15.20	25.6
TPHK 2T 6 -3	3MSWV-6-2	7.83	15.91	26.0
TPHK 2T 8 -3	3MSWV-8-2	9.25	17.32	26.9
TPHK 2T11-3	3MSWV-11-2	11.38	19.45	27.8
TPHK 2T 4 -4	4MSWV-4-2	6.42	14.49	25.4
TPHK 2T 6 -4	4MSWV-6-2	7.83	15.91	26.2
TPHK 2T 5 -5	5MSWV-5-2	7.13	16.77	28.0
TPHK 2T 6 -5	5MSWV-6-2	7.83	17.48	29.3
TPHK 2T 6 -6	6MSWV-6-2	7.83	17.80	29.8
TPHK 2T 8 -6	6MSWV-8-2	9.25	19.21	30.6
TPHK 2T 9 -6	6MSWV-9-2	9.96	19.92	31.1
TPHK 2T10-6	6MSWV-10-2	10.67	20.63	31.3
TPHK 2T11-6	6MSWV-11-2	11.38	21.34	31.7
TPHK 2T 7 -7	7MSWV-7-2	8.54	18.50	28.7
TPHK 4T 2 -1	1MSWV-2-4	5.71	13.78	23.8
TPHK 4T 3 -1	1MSWV-3-4	6.77	14.84	24.3
TPHK 4T 2 -2	2MSWV-2-4	5.71	13.78	24.3
TPHK 4T 3 -2	2MSWV-3-4	6.77	14.84	24.7
TPHK 4T 4 -2	2MSWV-4-4	7.83	15.91	25.1
TPHK 4T 6 -2	2MSWV-6-4	9.96	18.03	25.6
TPHK 4T 3 -3	3MSWV-3-4	6.77	16.42	25.8
TPHK 4T 4 -3	3MSWV-4-4	7.83	17.48	26.2
TPHK 4T 5 -3	3MSWV-5-4	8.90	18.54	26.7
TPHK 4T 6 -3	3MSWV-6-4	9.96	19.61	27.1
TPHK 4T 8 -3	3MSWV-8-4	12.09	21.73	28.0
TPHK 4T 4 -4	4MSWV-4-4	7.83	17.48	29.3
TPHK 4T 5 -4	4MSWV-5-4	8.90	18.54	29.8
TPHK 4T 6 -4	4MSWV-6-4	9.96	19.61	30.2
TPHK 4T 5 -5	5MSWV-5-4	8.90	18.54	30.6
TPHK 4T 8 -5	5MSWV-6-4	12.09	21.73	32.0
TPHK 4T 6 -6	6MSWV-6-4	9.96	19.92	31.1
TPHK 4T 8 -6	6MSWV-8-4	12.09	22.05	32.2
TPHK 4T 7 -7	7MSWV-7-4	11.02	20.98	32.2
TPHK 4T 8 -7	7MSWV-8-4	12.09	22.05	32.6
TPHK 8T 6 -2	2MSWV-6-8	7.83	22.36	52.9
TPHK 8T 9 -2	2MSWV-9-8	11.75	26.28	55.8
TPHK 8T 3 -3	3MSWV-3-8	3.76	18.29	50.7
TPHK 8T 6 -3	3MSWV-6-8	7.83	22.36	53.6
TPHK 8T 9 -3	3MSWV-9-8	11.75	26.28	56.4
TPHK 8T 4 -4	4MSWV-4-8	5.12	19.65	59.5
TPHK 8T 6 -4	4MSWV-6-8	7.83	22.36	61.7
TPHK 8T 5 -5	5MSWV-5-8	6.48	21.00	61.7
TPHK12T 6 -1	1MSWV-6-12	7.83	22.36	59.5
TPHK12T 6 -2	2MSWV-6-12	7.83	22.36	63.9
TPHK12T 9 -2	2MSWV-9-12	11.75	26.28	67.2

GENERAL TERMS OF SALE FOR PRODUCTS (Rev. June 2007)

1. GENERAL

A. Seller's price is based on these sales terms and conditions. The agreement and inclusion of other or amended terms in this contract will result in a change (including increase) in Seller's price (as may be contained in any price books or quotations) to reflect such other or amended terms. This contract shall represent the final, complete and exclusive statement of the agreement between the parties and may not be modified, supplemented, explained or waived by parole evidence, any Terms and Conditions contained in Buyer's purchase order or request for quotation, any course of dealings between the parties, Seller's performance or delivery, or in any other way. The Terms and Conditions of this contract may only be modified or waived in a written document signed by an Officer of Seller. These terms are intended to cover all activity of Seller and Buyer hereunder, including sales and use of products, parts and work and all related matters (references to products include parts and references to work include construction, installation and start-up). Any reference by Seller to Buyer's specifications and similar requirements are only to describe the products and work covered hereby and no warranties or other terms therein shall have any force of effect. Any information provided by Seller including, but not limited to, suggestions as to specific equipment does not imply any guarantee of specific suitability and/or material compatibility in a particular application, since many factors outside the control of Seller may affect the suitability of products in a particular application. Catalogs, circulars, similar pamphlets and information contained on websites of the Seller are issued for general information purposes only and shall not be deemed to modify the provisions hereof.

B. The agreement formed hereby and the language herein shall be construed and enforced under the Uniform Commercial Code as in effect in the State of California on the date hereof.

2. TAXES

Any sales, use or other similar type taxes imposed on this sale or on this transaction and/or any import or export duties or fees as may be assessed or imposed on or as a result of deliveries under this transaction are not included in the price. Such taxes shall be billed separately to the Buyer. Seller will accept a valid exemption certificate from the Buyer if applicable; however, if an exemption certificate previously accepted is not recognized by the governmental taxing authority involved and the Seller is required to pay the tax covered by such exemption certificate. Buyer agrees to promptly reimburse Seller for the taxes paid.

3. PERFORMANCE, INSPECTION AND ACCEPTANCE

A. Unless Seller specifically assumes installation, construction or start-up responsibility, all products shall be finally inspected and accepted within thirty (30) days after arrival at point of delivery. Where seller has responsibility for installation, construction or start-up all work shall be finally inspected and accepted within thirty (30) days after completion of the applicable work by Seller. All claims whatsoever by Buyer, (including claims for shortages) except only those provided for under the WARRANTY AND LIMITATION OF LIABILITY and PATENTS Clauses, hereof, must be asserted in writing by Buyer within said thirty (30) day period or they are waived. If this contract involves partial performance, all such claims must be asserted within said thirty- (30) day period for each partial performance. There shall be no revocation of acceptance. Rejection may be only for defects substantially impairing the value of products or work and Buyer's remedy for lesser defects shall be those provided for under the WARRANTY AND LIMITATION OF LIABILITY Clause.

B. Seller shall not be responsible for non-performance or for delays in performance occasioned by any causes beyond Seller's reasonable control, including, by way of example and not limitation, to labor difficulties, delays of vendors or carriers, fires, governmental actions, or shortages of material, components, labor, or manufacturing facilities. Any delays so occasioned shall affect a corresponding extension of Seller's performance dates, which are, in any event, understood to be approximate. IN NO EVENT SHALL BUYER BE ENTITLED TO INCIDENTAL OR CONSEQUENTIAL DAMAGES FOR LATE PERFORMANCE OR FOR A FAILURE TO PERFORM. Seller reserves the right to make partial shipments and to ship products, parts or work which may be completed prior to the scheduled performance date.

C. In the event that Seller has agreed to mount motors, turbines, gears, or other products which are not manufactured by Seller and which are not an integral part of Seller's manufactured product, and a delay in the delivery of such products to Seller occurs that will cause a delay in Seller's performance date, Seller reserves the right to ship its product upon completion of manufacture and to refund an equitable portion of the amount originally included in the purchase price for mounting without incurring liability for non-performance.

D. Seller reserves to itself the right to change its specifications, drawings and standards if such changes will not impair the performance of its products, and parts, and further those products, and parts, will meet any of Buyer's specifications and other specific product requirements which are a part of this agreement. Seller is a global supplier of products and utilizes parts and products obtained worldwide, and Seller's products supplied under this contract shall be subject to Seller's sole determination as to all manufacturing, sourcing, assembly and supply unless otherwise specifically agreed in writing.

E. The manufacture and inspection of products and parts shall be to Seller's Engineering and Quality Assurance standards, plus such other inspections or tests of documentation as are specifically agreed to by Seller. Requirements for any additional inspection, tests, documentation, or Buyer witness of manufacture, test, and/or inspection shall be subject to additional charges.

4. TITLE AND RISK OF LOSS

Title and risk of loss shall pass to buyer upon delivery of products at the designated "Ex Works" as defined by Incoterms, unless otherwise agreed by the parties.

5. EROSION AND CORROSION

It is specifically understood that products and parts sold hereunder are not warranted for operation with erosive or corrosive fluids or for operation with any fluid or under any operating condition in variance with the specifications of this contract. No product or part shall be deemed to be defective by reason of failure to resist erosive or corrosive action of any fluid and Buyer shall have no claim whatsoever against Seller therefore. No product shall be deemed defective by reason of any effect on Seller's products of the action or results (such as vibration) of any goods or system (such as piping) not supplied by Seller.

6. BUYER'S RESPONSIBILITY

The design specifications of the equipment require the operation of the equipment within certain parameters and may call for the use of speed controls, safety devices, set points or other control devices to insure that the operation remains within design parameters. Buyer agrees and understands that the equipment must be operated and maintained within design specifications and operated within the specifications of the contract, irrespective of whether controls or devices are otherwise required.

7. WARRANTY AND LIMITATION OF LIABILITY.

A. Seller warrants only that its product and parts, when shipped, will be free from defects in materials and workmanship. All claims for defective products or parts under this warranty must be made in writing immediately upon discovery and, in any event, within two (2) years of shipment by seller and all claims for defective work must be made in writing immediately upon discovery. Defective items must be held for Seller's inspection and returned to the sellers' point of original shipment upon request.

ANY UNAUTHORIZED DISSASSEMBLY, ALTERATION OF OR TAMPERING WITH ANY PRODUCT OR COMPONENT MAY "VOID" THE WARRANTY, IN THAT SUCH ACTION WILL RESULT IN SELLER BEING RELEASED AND RELIEVED FROM ITS OBLIGATIONS UNDER THIS WARRANTY AND FOR ANY FURTHER COSTS OR ACTIONS UNDER CLAUSE 7.C, FOLLOWING, AND THE BUYER ASSUMING SOLE RESPONSIBILITY FOR THE COSTS AND RESULTS OF SUCH ACTION.

THE FOREGOING IS EXPRESSLY IN LIEU OF ALL OTHER WARRANTIES WHATSOEVER, EXPRESS, IMPLIED AND STATUTORY, INCLUDING WITHOUT LIMITATION, THE IMPLIED, WARRANTIES OF MERCHANTABILITY AND FITNESS.

B. ANY PRODUCT (S) SOLD HEREUNDER WHICH ARE NOT MANUFACTURED BY SELLER ARE NOT WARRANTED BY SELLER and shall be covered only by the express warranty, if any, of the manufacturer thereof. With respect to products and parts not manufactured by Seller, Seller's only obligation shall be to assign to Buyer, to the extent possible, whatever warranty Seller obtains from the manufacturer.

C. Upon Buyer's submission of a claim as provided above and its substantiation, Seller shall at its option either (i) repair or replace its product, part or work at the original place of shipment, or (ii) refund an equitable portion of the purchase price.

D. THE FOREGOING IS SELLER'S ONLY OBLIGATION AND BUYER'S EXCLUSIVE REMEDY FOR BREACH OF WARRANTY AND, EXCEPT FOR THE REMEDIES PERMITTED UNDER THE PERFORMANCE, INSPECTION AND ACCEPTANCE AND THE PATENTS CLAUSES HEREOF, THE FOREGOING IS BUYER EXCLUSIVE REMEDY AGAINST SELLER FOR ALL CLAIMS ARISING HEREUNDER OR RELATING HERETO WHETHER SUCH CLAIMS ARE BASED ON BREACH OF CONTRACT, TORT (INCLUDING NEGLIGENCE OR STRICT LIABILITY), INDEMNITY OR OTHER THEORIES. BUYER'S FAILURE TO SUBMIT A CLAIM AS PROVIDED ABOVE SHALL SPECIFICALLY WAIVE ALL CLAIMS FOR DAMAGES OR OTHER RELIEF, INCLUDING BUT NOT LIMITED TO CLAIMS BASED ON LATENT DEFECTS. IN NO EVENT SHALL BUYER BE ENTITLED TO INDIRECT, SPECIAL, INCIDENTAL OR CONSEQUENTIAL DAMAGES, NOR FOR DAMAGES FOR LOSS OF USE, LOST PROFITS OR REVENUE, INTEREST, LOST GOODWILL, WORK OR PRODUCTION STOPPAGE, IMPAIRMENT OF OTHER GOODS, INCREASED EXPENSES OF OPERATION, OR THE COST OF PURCHASING REPLACEMENT POWER OR OTHER SERVICES BECAUSE OF SERVICE INTERRUPTIONS. FURTHERMORE, IN NO EVENT SHALL SELLER'S TOTAL LIABILITY FOR DAMAGES OF BUYER EXCEED THE PURCHASE PRICE OF THE PRODUCTS OR PARTS MANUFACTURED BY SELLER AND UPON WHICH SUCH LIABILITY IS BASED. ANY ACTION ARISING HEREUNDER RELATED HERETO, WHETHER BASED ON BREACH OF CONTRACT, TORT (INCLUDING NEGLIGENCE) OR OTHER THEORIES, MUST BE COMMENCED WITHIN ONE (1) YEAR AFTER THE CAUSE OF ACTION ACCRUES OR IT SHALL BE BARRED.

8. PURCHASER'S REPRESENTATIONS & WARRANTIES

Purchaser represents and warrants that the products(s) covered by this contract shall not be used in or in connection with a nuclear facility or application. The parties agree that this representation and warranty is material and is being relied on by seller. This provision may be modified in a separate writing signed by an officer of Price Pump Co.

9. PATENTS

Seller agrees to assume the defense of any suit for infringement of any patents brought against Buyer to the extent of such suit charges infringement of an apparatus or product claim by Seller's product in and of itself, provided (i) said product is built entirely to Seller's design, (ii) Buyer notifies Seller in writing of the filing of such suit within ten (10) days after the service of process thereof, and (iii) Seller is given complete control of the defense of such suit, including the right to defend, settle and make changes in the product for the purpose of avoiding infringement of any process or method claims. Provided however, Seller will not defend any suit for infringement of a claimed patent where such alleged infringement is the result of following specific instruction furnished by Seller.

10. EXTENT OF SUPPLY

Only products as listed in Seller's proposal are included in this agreement. It must not be assumed that Seller has included anything beyond same.

11. MANUFACTURING SOURCES

To maintain delivery schedules, Seller reserves the right to have all or any part of the Buyer's order manufactured at any of Sellers', sellers' licensees or sub contractors' plants, globally.

12. TERMS OF PAYMENT

Net 30 days from date of invoice.

13. ARBITRATION

In the event a dispute arises between the parties relating to or arising out of this agreement, the parties agree to attempt to have their senior management amicably settle the matter. In the event that the matter cannot be settled, the parties shall submit all disputes relating to this Agreement (whether contract, tort, products liability or otherwise) to binding Arbitration before a panel of arbitrators under the Commercial Dispute Resolution Procedures of the American Arbitration Association. Each party shall appoint an arbitrator and the third shall be selected in accordance with the rules of the American Arbitration Association. Judgment upon the award may be entered in any court having jurisdiction. The parties shall cooperate in providing reasonable disclosure of relevant documents. Each party shall bear its own expenses, and the costs and fees of the arbitration shall be borne as allocated by the Arbitrator.

CALL 1-800-577-8111 FOR SALES AND SUPPORT
CLICK FOR PRICE PUMPS WEBSITE

Multi-stage Centrifugal Pumps



CALL 1-800-577-8111 FOR SALES AND SUPPORT
CLICK FOR PRICE PUMPS WEBSITE