



®
PRICE® PUMP
Installation,
Operating, and
Maintenance
Manual

Type OH75

Caution:
Before installing, repairing
or performing maintenance
on this pump, read these
instructions completely.

Installation
Electrical

WARNING!
Ground motor before
connecting to electrical
power supply! Failure to
ground motor can cause
severe or fatal electrical
shock hazard!

Do not ground to gas
supply line!

Disconnect power to motor
before working on motor
or pump!

Match voltage to
nameplate voltage on
motor. Incorrect voltage
can cause fire or seriously
damage motor, voiding
warranty.

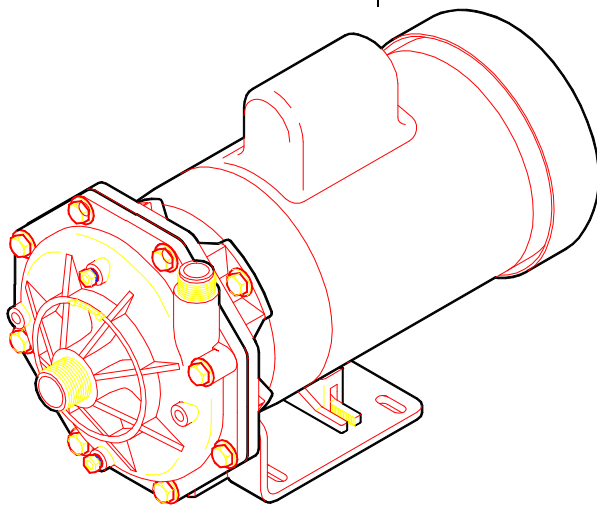

Close Coupled -
Motor Pumps

These pumps require no special
care in mounting, although it is
suggested that they be firmly
bolted to a level surface.
Adequate air movement over
motor will help prevent overloads.

Power Frame Mounted
Pumps

These pumps must be mounted on
a rigid steel base that will not
warp or flex. Each pump must be
mounted such that **the pump**
shaft centerline is on center
with the driver shaft center-line.
Pads and/or shims will be
required on either pump, driver or
both. The two shafts should not
touch each other and the distance
between them depends on the
coupling used to connect them.
Misalignment will cause
bearing failure and void
warranty. Pumps are rough
aligned at the factory but must
be realigned after shipment and
installation. Pulley driven pumps
must have pulleys in line and
good belt tightness practices
followed.

Direction of Rotation

Note: Motor shaft rotation is viewed from the suction end of pump. A rotational arrow is shown on the front of the pump volute casing. Incorrect rotation can cause pump damage, failure or reduced performance, voiding warranty. It is best to check rotation by **momentarily** energizing or jogging the motor prior to filling pump with liquid.

Warning! Do not operate pump without liquid for more than a few seconds, as damage will result to mechanical seal.

PLUMBING

All piping should be supported independently of the pump. Piping should not exert any stress on the pump connections.

1. Suction Piping-Horizontal Pumps.

Suction line must provide adequate suction pressure and smooth liquid flow for proper pump operation. Air entrapment in the suction line because of leaks or improper design may cause the pump to lose prime and fail. This pump is not self-priming, therefore the suction must be flooded at start up. Also, the suction line must provide sufficient pressure and smooth flow to pump inlet to prevent pump cavitation. A length of straight pipe a minimum of 5 times the pump inlet diameter and preferably 10 times

the diameter should be installed in the suction line where it enters the pump. Elbows, fittings or valves installed close to the suction can disrupt liquid flow and cause malfunction. Suction lines must be at least the same size as the pump inlet or larger if possible. Price Pump Company recommends against using foot valves in the suction line to maintain liquid in the pump when it's not operating. If foot valves are used due to suction lift conditions they must be properly maintained to avoid leaks resulting from wear or fouling. Suction piping must be designed to prevent air from being trapped in high spots in the piping. This condition may cause the pump to vapor lock as the air bubble moves into the pump.

2. Discharge Piping.

For flow and discharge head control it is advisable to install a valve (globe, ball, or other adjustable and non-leak type) in the discharge line close to the pump. The valve may be closed during system repairs to prevent backflow. By installing a check valve in the discharge line backflow can also be prevented during maintenance or during periods of pump stoppage.

OPERATION

Priming. All centrifugal pumps must be filled with liquid prior to start up. For the OH pump illustrated in this manual completely fill the volute and suction lines prior to operation. It is suggested that during initial start up the discharge valve be closed and then opened as the motor develops full rpm's. If pump does not build up pressure as motor speed increases, shut down and reprime pump. Make sure that liquid flow into pump is not restricted (see "Troubleshooting").

Note: A centrifugal pump's flow and head (pressure) will vary with the amount of resistance (friction and flow restrictions) in the discharge line. As a valve on the discharge line opens the flow and motor amp draw will increase and head will drop. As a valve on the discharge is closed the flow and amp draw will decrease and the head will increase. If resistance in the discharge line is not sufficient the pump will operate at a condition of maximum (or "choked") flow, also sometimes called "end of performance curve." Maximum horsepower is required to operate at this point and motor overload may result. If excessive amp draw and motor overload is recurring, reduce the system flow by installing a valve on the discharge line and restricting flow. Alternatively, reduce pump head by trimming impeller to a smaller diameter. Consult local Price Pump dealer for assistance.

CAUTION

Disconnect power to pump before servicing to avoid dangerous or fatal electrical shock hazards.

If pump has been used to pump hazardous materials be certain that all materials have been removed prior to working on the pump.

Inverting pump with liquid in it could cause liquid to get into motor bearings and cause damage. Before disassembling be certain all liquid is removed from the pump.

TROUBLESHOOTING

1. Pump fails to build pressure:

Check for:

- a. Pump not primed.
- b. Incorrect rotation.
- c. Driver speed too low.
- d. Suction line restricted.
- e. Driver failure.
- f. Plugged or damaged impeller.
- g. Pump or impeller undersized.
- h. Pump cavitation.
- i. Impeller rubbing volute.

2. Pump fails to provide enough flow.

Check for:

- a. System resistance too high.
- b. Pump undersized.
- c. Pump not primed.
- d. Driver speed too low.
- e. Poor suction conditions
- f. Impeller rubbing volute due to improper installation.
- g. Pump cavitation.
- h. Plugged or damaged impeller.

3. Excessive noise or vibration during operation.

Check for:

- a. Motor bearing failing.
- b. Pump cavitating.
- c. Impeller rubbing volute.

4. Leaking mechanical seal.

Check for:

- a. Improper assembly.
- b. Worn or cracked seal faces.
- c. Abrasive material build up around seal.
- d. Liquid flashing at seal faces (temp too high).
- e. Seal pressure rating too low for the service.
- f. Chemical attack of seal parts.
- g. Seal operated dry or with a liquid having poor lubricating properties.

5. Pump gradually loses pressure and head.

Check for:

- a. Increasing temperature causing cavitation or liquid vaporization.
- b. Driver failure.
- c. Suction lift too high.
- d. Air entering suction line.

6. Motor/pump overheating.

Check for:

- a. Excessive flow and amp draw. (Throttle discharge)
- b. Low voltage or frequency.
- c. Flow too low with resulting heat rise.
- d. Bearing failure.
- e. System temperature too high.

TYPE OH75 MAINTENANCE AND REPAIR

I&O IN 147-5

Before attempting any repairs under warranty, contact Distributor to obtain factory authorization. Repairs carried out without authorization may void warranty. Many causes of pump system failure are due to improper system design. Refer to the Trouble Shooting List in this manual before carrying out pump inspection.

DISASSEMBLY		REASSEMBLY
<ol style="list-style-type: none">1. Disconnect power source from motor.2. Disconnect electrical connections, tagging wires carefully to preserve correct rotation. Loosen pump base.3. Remove pump and motor assembly to repair area. Observe position of all parts prior to disassembly.4. Remove 8 volute bolts and remove volute from pump.5. Remove split collar from impeller sleeve. Loosen two Allen cap screws and setscrew in split collar. Slide impeller off of the motor shaft.6. Remove seal head from the shaft sleeve. Remove seal by sliding it off of the shaft sleeve.	<ol style="list-style-type: none">7. Remove the four motor bolts and remove bracket from motor.8. Remove seal seat from bracket. Use wooden or plastic dowel to tap the seat from the bracket.	<ol style="list-style-type: none">1. Place the bracket on a firm surface with the seat cavity (pump end) up.2. Clean seal cavity of the bracket thoroughly.3. Place the seat in the seal cavity with the polished face up toward the pump end (lubricate elastomer with water to ease seat installation). Evenly push seat into seat cavity with fingers, then gently tap seat into place with a wooden dowel or plastic rod (1-1/2" outside diameter).4. Install seal head assembly:<ol style="list-style-type: none">a. Thorough clean impeller sleeve. Assure that the shaft is not grooved and that there is no evidence of pitting or fretting under the seal head.b. Install rotary seal head onto impeller sleeve with the carbon facing away from the impeller. Using a twisting motion slide seal head all the

way up to the hub of the impeller.

5. Place the sleeve of the impeller through the ceramic seat until carbon touches ceramic. Place the split collar around the end of the sleeve so that it is flush with the end of the sleeve. Align the center setscrew until it enters the impeller sleeve hole. Do not tighten. Snug the capscrews in the split collar at this time.
6. Install volute.
 - a. Lubricate the volute O-ring with water only.

Warning: Organic oils will attack CPVC and cause stress cracks.

- b. Place the O-ring around the register fit on the bracket. Place the volute on the bracket over the O-ring and squeeze together with two hands.

Note: The discharge must be aligned with the bracket so that the discharge is pointing up in the same direction as the seal flush boss on the pump bracket. The volute will only fit this one way. To rotate volute discharge position you must rotate the bracket on the motor.

- c. Install volute bolts, washers and nuts. Tighten all eight bolts evenly to 8-10 ft./lbs.

Installing Pump End onto Motor

1. Thoroughly clean motor shaft. Assure that the shaft and keyway have no burrs. Polish the shaft with extra fine emery cloth and clean the keyway.
2. With motor resting on flat surface, shaft end up, carefully place assembled pump end onto motor shaft. Be sure to align key in impeller sleeve with keyway in motor shaft.
3. Install motor bolts and base (if applicable). Tighten motor bolts evenly.
4. Using a screwdriver or 3/4" diameter rod inserted through the suction of the pump, gently push the impeller down onto the motor shaft until it bottoms out on the shaft. Align center cup pt. setscrew in split collar with hole in impeller sleeve. It must clear all sides of locating hole to ensure full contact with motor shaft. Tighten two Allen capscrews in the split collar to 8-10 ft./lbs. The center cup pt. must

remain loose until the two Allen capscrews are tight. Tighten center cup pt. setscrew to 4-5 ft./lb.

5. After assembly of pump end to motor, the unit must be checked to insure the shaft and impeller rotate freely. If not, loosen setscrews and repeat step 7.
6. Return pump to installation, reconnect electric connections.
7. Start pump momentarily to observe shaft rotation. If rotation corresponds to the rotation arrow on the pump, it may be put into service. If rotation is incorrect, switch any two leads on 3-phase motors to change rotation. Check wiring diagram of motor for single phase rotation correction.
8. Remove top pipe plug (if applicable) from the front of volute and prime pump thoroughly, making sure all air is purged. Turn shaft one revolution and then refill. Replace the pipe plug.
9. Start pump allowing adequate time to purge all air from system. Observe any gauges, flow meters, etc., to see if pump performs properly.



PRICE PUMP CO.

TYPE OH75 PARTS LIST

Effective: November 17, 1997

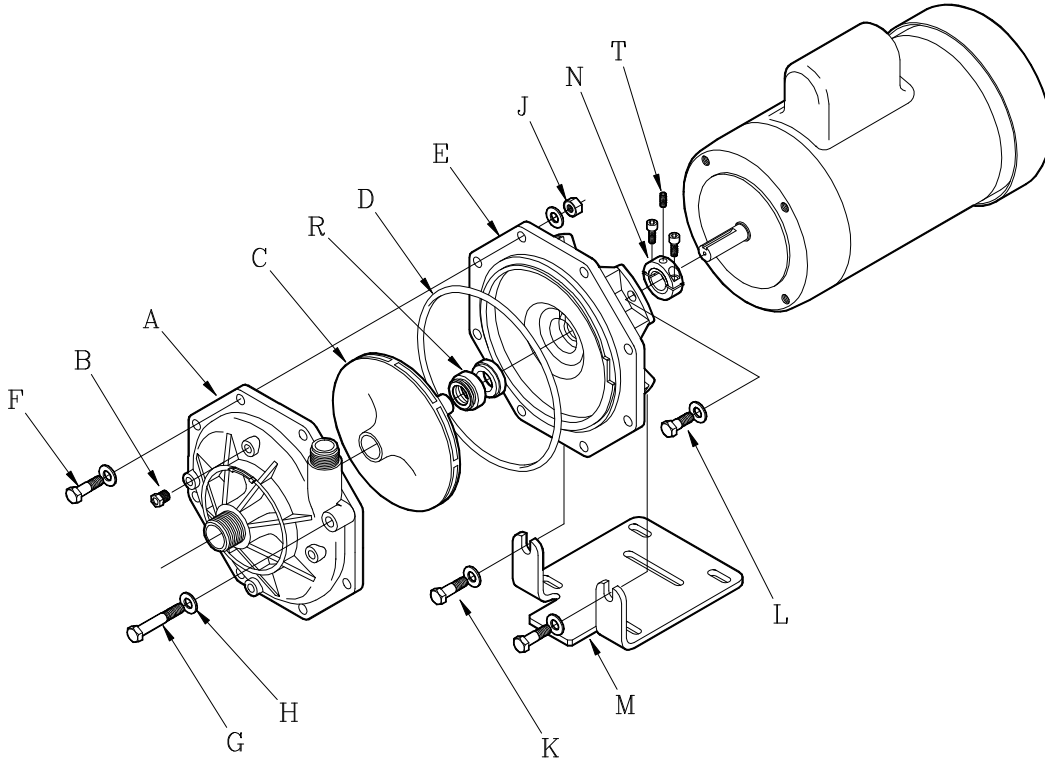
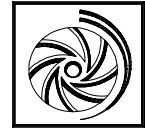

CP = CPVC
PF = PVDF

	<u>CPVC</u>	<u>All Models</u>	<u>PVDF</u>
A. Volute	8010CP		8010PF
B. Pipe Plug (2 rqd)		8012PF	
C. Impeller	8020CP Imp. Dia.		8020PF Imp. Dia.
D. 'O'Ring (choice of P/N)			
Viton® (Std)	8073VN (Std)		8075VN
EPR	8073EP		8075EP
Buna	8073BN		
E. Bracket	8014CP		8014PF
F. Volute Bolts (7 rqd)		3148	
G. Volute Bolts - Long (1 rqd)		3084	
H. Washer (20 rqd)		3081	
J. Nut (8 rqd)		3082	
K. Motor Bolt - Long (2 rqd)		0592	
L. Motor Bolt - Short (2 rqd)		0587	
M. Base		8016	
N. Collar, Split		8018	
R. Seal with Seat			
T.36 Viton® 1" (std)		8302-211	
T.36 EPR 1" P/N 8302-511		Contact Factory	
T. Setscrew		0570	



PRICE PUMP CO.

OH75 OUTLINE DRAWING

Effective: JANUARY 1, 1993

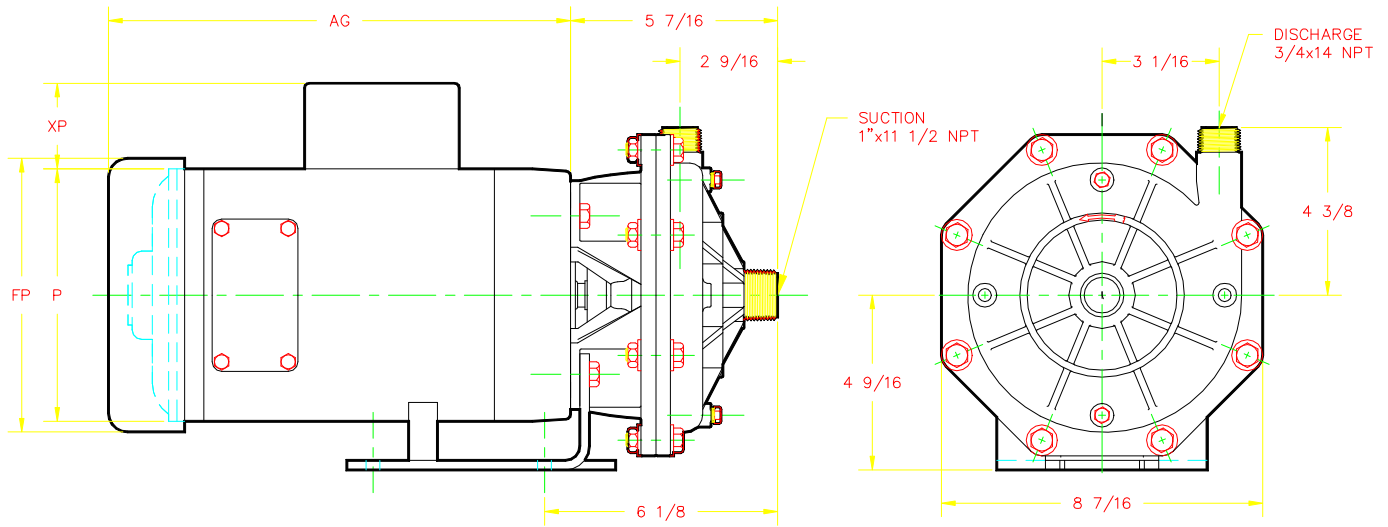
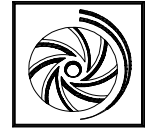

MOTOR END DIMENSIONS						
HP	RPM	FRM	AG	FP	P	XP
1/4	1800	56C	7 3/4	7 3/16	6 7/8	2 1/16
1/3	1800	56C	8 1/4	7 3/16	6 7/8	2 1/16
1/2	1800	56C	8 3/4	7 3/16	6 7/8	2 1/16
1/3	3600	56C	8 1/2	7 3/16	6 7/8	2 1/16
1/2	3600	56C	8 3/4	7 3/16	6 7/8	2 1/16
3/4	3600	56C	9 1/4	7 3/16	6 7/8	2 1/16
1	3600	56C	9 3/4	7 3/16	6 7/8	2 1/16
1 1/2	3600	56C	10 1/2	7 3/16	6 7/8	2 1/16
2	3600	56C	11 1/8	7 3/16	6 7/8	2 1/16
3	3600	56C	12 3/8	7 3/16	6 7/8	2 1/16

NOTE:
 MOTOR DIMENSIONS WILL VARY BY MODEL AND MAKE,
 DIMENSIONS ARE TO BE USED FOR REFERENCE ONLY.

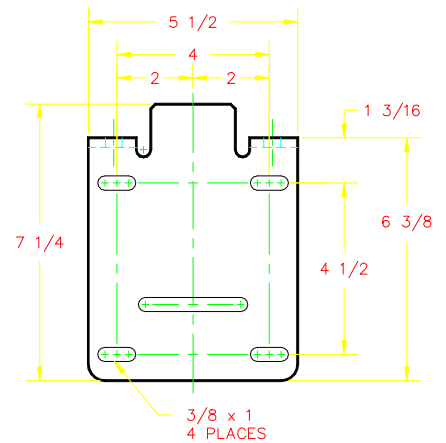

NOTE:
 1. PUMP MATERIAL IS POLYPROPYLENE OR POLYVINYLIDENE FLUORIDE (PVDF).
 2. ALL DIMENSIONS ARE ROUNDED TO THE NEAREST SIXTEENTH OF AN INCH.



GENERAL TERMS OF SALE FOR PRODUCTS

Effective: January 1, 1993

1. GENERAL

A. Seller's price is based on these sales terms and (i) this document together with any additional writings signed by Seller shall represent the final, complete and exclusive statement of the agreement between the parties and may not be modified, supplemented, explained or waived by parol evidence, Buyer's purchase order, a course of dealing, Seller's performance or delivery, or in any other way except in writing signed by an authorized representative of Seller, and (ii) these terms are intended to cover all activity of Seller and Buyer hereunder, including sales and use of products, parts and work and all related matters (references to products include parts and references to work include construction, installation and start-up). Any reference by Seller to Buyer's specifications and similar requirements are only to describe the products and work covered hereby and no warranties or other terms therein shall have any force of effect. Catalogs, circulars and similar pamphlets of the Seller are issued for general information purposes only and shall not be deemed to modify the provisions hereof.

B. The agreement formed hereby and the language herein shall be construed and enforced under the Uniform Commercial Code as in effect in the State of California on the date hereof.

2. TAXES

Any sales, use or other similar type taxes imposed on this sale or on this transaction are not included in the price. Such taxes shall be billed separately to the Buyer. Seller will accept a valid exemption certificate from the Buyer if applicable; however, if an exemption certificate previously accepted is not recognized by the governmental taxing authority involved and the Seller is required to pay the tax covered by such exemption certificate. Buyer agrees to promptly reimburse Seller for the taxes paid.

3. PERFORMANCE, INSPECTION AND ACCEPTANCE

A. Unless Seller specifically assumes installation, construction or start-up responsibility, all products shall be finally inspected and accepted within thirty (30) days after arrival at point of delivery. Products not covered by the foregoing and all work shall be finally inspected and accepted with thirty (30) days after completion of the applicable work by Seller. All claims whatsoever by Buyer (including claims for shortages) excepting only those provided for under the WARRANTY AND LIMITATION OF LIABILITY and PATENTS Clauses hereof must be asserted in writing by Buyer within said thirty (30) day period or they are waived. If this contract involves partial performance, all such claims must be asserted within said thirty (30) day period for each partial performance. There shall be no revocation of acceptance. Rejection may be only for defects substantially impairing the value of products or work and Buyer's remedy for lesser defects shall be those provided for under the WARRANTY AND LIMITATION OF LIABILITY Clause.

B. Seller shall not be responsible for non-performance or for delays in performance occasioned by any causes beyond Seller's reasonable control, including, but not limited to, labor difficulties, delays of vendors or carriers, fires, governmental actions, or shortages of material, components, labor, or manufacturing facilities. Any delays so occasioned shall affect a corresponding extension of Seller's performance dates which are, in any event, understood to be approximate. In no event shall Buyer be entitled to incidental or consequential damages for late performance or for a failure to perform. Seller reserves the right to make partial shipments and to ship products, parts or work which may be completed prior to the scheduled performance date.

C. In the event that Seller has agreed to mount motors, turbines, gears, or other products which are not manufactured by Seller and which are not an integral part of Seller's manufactured product, and a delay in the delivery of

such products to Seller occurs that will cause a delay in Seller's performance date, Seller reserves the right to ship its product upon completion of manufacture and to refund an equitable portion of the amount originally included in the purchase price for mounting without incurring liability for non-performance.

D. Seller reserves to itself the right to change its specifications, drawings and standards if such changes will not impair the performance of its products, and parts, and further that such products, and parts, will meet any of Buyer's specifications and other specific product requirements which are a part of this agreement.

E. The manufacture and inspection of products and parts shall be to Seller's Engineering and Quality Assurance standards plus such other inspections, tests of documentation as are specifically agreed to by Seller. Requirements for any additional inspection, tests, documentation, or Buyer witness of manufacture, test, and/or inspection shall be subject to additional charges.

4. TITLE AND RISK OF LOSS

Title and risk of loss shall pass to buyer upon delivery of products at the designated Ex Works place (Incoterms 1990) unless other wise agreed by the parties. **See Reverse**

5. EROSION AND CORROSION

It is specifically understood that products and parts sold hereunder are not warranted for operation with erosive or corrosive fluids. No product or part shall be deemed to be defective by reason of failure to resist erosive or corrosive action of any fluid and Buyer shall have no claim whatsoever against Seller therefore.

6. WARRANTY AND LIMITATION OF LIABILITY.

A. Seller warrants only that its product and parts, when shipped, and its work (including installation, construction and start-up), when performed will meet all applicable specifications and other specific product and work requirements (including those of performance), if any, of this agreement, and will be free from defects in materials and workmanship. With respect to products, parts and work not manufactured or performed by Seller, Seller's only obligation shall be to assign to Buyer, to the extent possible, whatever warranty Seller requires from the manufacturer. All claims for defective products or parts under this warranty must be made in writing immediately upon discovery and, in any event, within one (1) year after initial start-up or eighteen (18) months after shipment, whichever first occurs, and all claims for defective work must be made in writing immediately upon discovery and in any event, within one (1) year of completion thereof by Seller. Defective items must be held for Seller's inspection and returned to the original f.o.b. point upon request. THE FOREGOING IS EXPRESSLY IN LIEU OF ALL OTHER WARRANTIES WHATSOEVER, EXPRESS, IMPLIED AND STATUTORY, INCLUDING WITHOUT LIMITATION, THE IMPLIED, WARRANTIES OF MERCHANTABILITY AND FITNESS.

B. Upon Buyer's submission of a claim as provided above and its substantiation, Seller shall at its option either (i) repair or replace its product, part or work at the original place of delivery, or (ii) refund an equitable portion of the purchase price.

C. THE FOREGOING IS SELLER'S ONLY OBLIGATION AND BUYER'S EXCLUSIVE REMEDY FOR BREACH OF WARRANTY AND, EXCEPT FOR GROSS NEGLIGENCE, WILLFUL MISCONDUCT, AND REMEDIES PERMITTED UNDER THE PERFORMANCE, INSPECTION AND ACCEPTANCE AND THE PATENTS CLAUSES HEREOF, THE FOREGOING IS BUYER EXCLUSIVE REMEDY AGAINST SELLER FOR ALL CLAIMS ARISING

HEREUNDER OR RELATING HERETO WHETHER SUCH CLAIMS ARE BASED ON BREACH OF CONTRACT, TORT (INCLUDING NEGLIGENCE) OR OTHER THEORIES. BUYER'S FAILURE TO SUBMIT A CLAIM AS PROVIDED ABOVE SHALL SPECIFICALLY WAIVE ALL CLAIMS FOR DAMAGES OR OTHER RELIEF, INCLUDING BUT NOT LIMITED TO CLAIMS BASED ON LATENT DEFECTS. IN NO EVENT SHALL BUYER BE ENTITLED TO INDIRECT, SPECIAL, INCIDENTAL OR CONSEQUENTIAL DAMAGES, NOR FOR DAMAGES FOR LOSS OF USE, LOST PROFITS OR REVENUE, INTEREST, LOST GOODWILL, WORK OR PRODUCTION STOPPAGE, IMPAIRMENT OF OTHER GOODS, INCREASED EXPENSES OF OPERATION, OR THE COST OF PURCHASING REPLACEMENT POWER OR OTHER SERVICES BECAUSE OF SERVICE INTERRUPTIONS. FURTHERMORE, IN NO EVENT SHALL SELLER'S TOTAL LIABILITY FOR DAMAGES OF BUYER EXCEED THE PURCHASE PRICE OF THE PRODUCTS OR PARTS MANUFACTURED BY SELLER AND UPON WHICH SUCH LIABILITY IS BASED. ANY ACTION ARISING HERE-UNDER OR RELATED HERETO, WHETHER BASED ON BREACH OF CONTRACT, TORT (INCLUDING NEGLIGENCE) OR OTHER THEORIES, MUST BE COMMENCED WITHIN ONE (1) YEAR AFTER THE CAUSE OF ACTION ACCRUES OR IT SHALL BE BARRED.

7. PATENTS

Seller agrees to assume the defense of any suit for infringement of any patents brought against Buyer to the extent of such suit charges infringement of an apparatus or product claim by Seller's product in an of itself, provided (i) said product is built entirely to Seller's design, (ii) Buyer notifies Seller in writing of the filing of such suit within ten (10) days after the service of process thereof, and (iii) Seller is given complete control of the defense of such suit, including the right to defend, settle and make changes in the product for the purpose of avoiding infringement of any process or method claims, unless infringement of such claims is the result of following specific instruction furnished by Seller.

8. EXTENT OF SUPPLY

Only products and listed in Seller's proposal are included in this agreement. It must not be assumed that Seller has included anything beyond same.

9. MANUFACTURING SOURCES

To maintain delivery schedules, Seller reserves the right to have all or any part of the Buyer's order manufactured at any of Seller's or its licensee's plants on a world-wide basis.

10. TERMS OF PAYMENT

Refer to following page for Terms of Payment.

(Terms3-/93Bob)